

US WHEELER

Industrial Robot + CNC Machinetools + Intelligent Factory

HANGZHOU WHEELER GENERAL MACHINERY INCORPORATED CO.,LTD

Add:

No.288 Shunfeng Road, Linping District, Hangzhou, Zhejiang, China

Tel:

+86 571 8369 5216

Fax:

+86 571 8369 5836

E mail:

info@wheeler-us.com

400 780 1898

24/7 Service Hotline.

Machine Tool Lifetime Service

We provide on-call service 24/7. If you encounter any equipment maintenance and repair problems, please contact us. If you have any suggestions, please log in to the company's official website to leave a message.
www.wheeler-us.com



Sample parameters and information are subject to change without prior notice, and the final data is subject to the technical agreement.

HL-LM02306-01-1000



For more information please follow Official WeChat account

LM Series

GANTRY MACHINING CENTER



US WHEELER

INDUSTRIAL ROBOT/
CNC MACHITOLS/
SMART FACTORY

ABOUT US

Hangzhou Wheeler Intelligent General Machinery Incorporated Co.,Ltd is a national high-tech enterprise focusing on CNC machining equipment, machine tool loading and unloading automation, digital factories, and non-standard fixture design and manufacturing. The company was established in January 2015, and its operation center is located in Linping Economic Development Zone, Hangzhou. The company currently has more than 300 employees and an efficient professional technical R&D team, including more than 60 professional and technical personnel with various intermediate and senior technical titles (engineers). The company has a 5,000 square meter R&D center and a 43,000 square meter production and debugging base, and owns more than 50 patent technologies. It has offices and after-sales service outlets in Shanghai, Jiangsu, Anhui, Shandong, Henan, Jilin, Chongqing, Ningbo, Taizhou, Wuhan, Xi'an, Zhengzhou, etc. The company's products are exported to Turkey, Egypt, South Africa, Brazil, Australia, Singapore, Malaysia, Thailand and other countries.

Our
Certification



The company's main products include machining equipment, machine tool loading and unloading robots, machine tool fixtures, peripheral automated logistics equipment, and robot integration systems. It is a strategic partner of robot companies such as Germany's KUKA and Switzerland's ABB. It provides customers with mechanical processing automation technology solutions, a full set of automation equipment, technical consulting, and comprehensive after-sales and technical services. The products are widely used in mass production industries such as automotive parts processing and engineering machinery.



Gantry series machining center

LM series gantry machining center is a high-end technology-intensive product of high quality, high precision and high performance carefully designed and manufactured by US Wheeler for you. The design of this machine tool is novel, the overall structure is beautiful and elegant, the accuracy of the machine tool is stable, the performance is reliable, and the operation is flexible and convenient.

Gantry series machining center

The Z-axis uses nitrogen hydraulic counterweight to ensure stable and reliable balance quality.

The X/Y axis adopts roller linear guides, and the Z axis adopts roller linear guides or box way, which greatly increases the load carrying capacity and improves the positioning accuracy, repeatable positioning accuracy and rigidity of the machine tool.

The worktable is supported throughout the entire travel, sharing the load evenly, with low wear, and ensuring that the worktable is small in suspension and deformation.

The crossbeam linear guide adopts non-co-directional arrangement and widened box structure saddle, which greatly improves the Y-axis rigidity and improves the cutting ability.

The enlarged crossbeam contact area effectively avoids vibration caused during processing.

The lubrication of machine tools adopts a volumetric system, with regular and quantitative automatic centralized oil supply for lubrication, ensuring that the lubricating parts are fully lubricated.



+ Tool magazine

The optional ATC tool magazine shortens tool changing time and provides sufficient tool storage to improve processing efficiency.

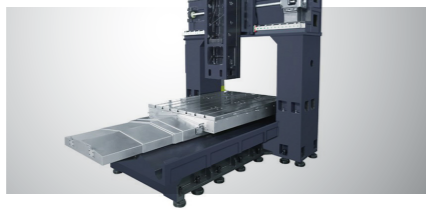

+

The overweight load-bearing machine body structure is supported by oversized columns and horizontally dyed box structures (the bottom track support is strengthened). The machine head ribs are completely arranged. The whole machine has good rigidity and can realize heavy cutting of large workpieces and molds.



+ Machine bed

The bed adopts a long-span design, which effectively reduces machine tool vibration and further enhances the stability of high-speed movement of machine tool moving parts. High-strength columns and long-span bed build the foundation for high-performance machine tools.



+ Y axis

The Y-axis adopts linear guides, which prevents crawling at low speeds. At the same time, it adopts the guide way step structure design, which not only ensures the rigidity of the gantry frame, but also reduces the overturning moment of the saddle and ram.

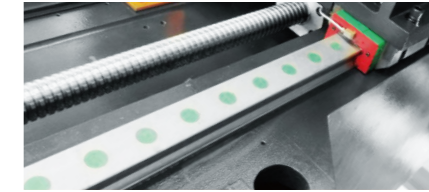

+ Roller type sliding block

The use of roller linear guides greatly increases the load carrying capacity and enhances the positioning accuracy, repeatability accuracy and rigidity of the machine tool.

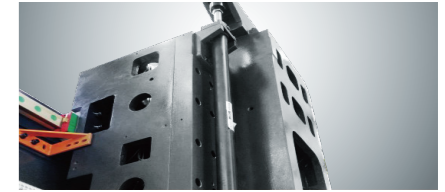

+ Z axis

The Z-axis uses nitrogen hydraulic counterweight to ensure stable and reliable balance quality.

BASIC STRUCTURE

Finite element analysis was conducted on the machine tool structure at various stages from basic design to ensuring high-speed and high-precision continuous processing. Simulation experiments were conducted on the deformation caused by the machine tool center bearing load to ensure the excellent bending rigidity of the machine tool.

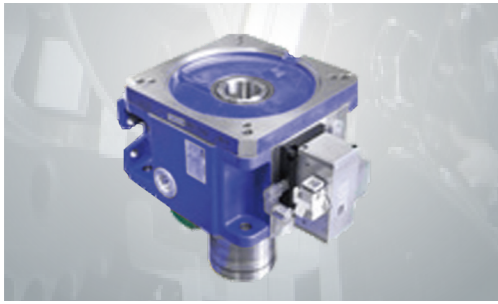

Gearbox

The spindle is optionally equipped with a two-speed gearbox to increase the spindle output torque.



Automatic side milling head

Optional automatic side milling head enables five-sided processing (limited to models with a door width of 2300 or above).

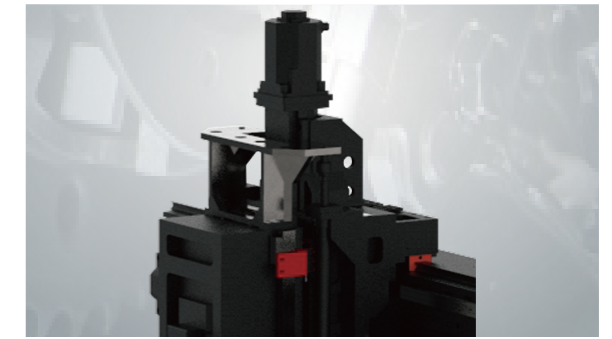

Nitrogen balance cylinder

The weight of spindle head is balanced to achieve high speed and high accuracy machining.

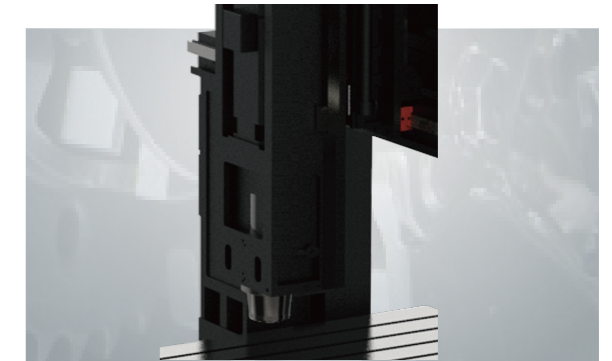

T-shaped ram structure

The rectangular structure has built-in reinforced shin plate which can withstand high torque.



Worktable

There are two longitudinal spiral chip conveyors and one transverse chain chip conveyor as standard.

KEY COMPONENT



The automatic tool changer (optional) consists of tool magazine and tool change arm. The automatic tool changer is integrally connected to the machine tool, which can effectively shorten the tool change time. The tool selection adopts the shortest path and fixed position method. All tools can return to their original positions, so the large tool collision problem only needs to be considered once during initial installation. The bidirectional tool magazine uses the shortest path.

Tool specifications

- BT - 40/50

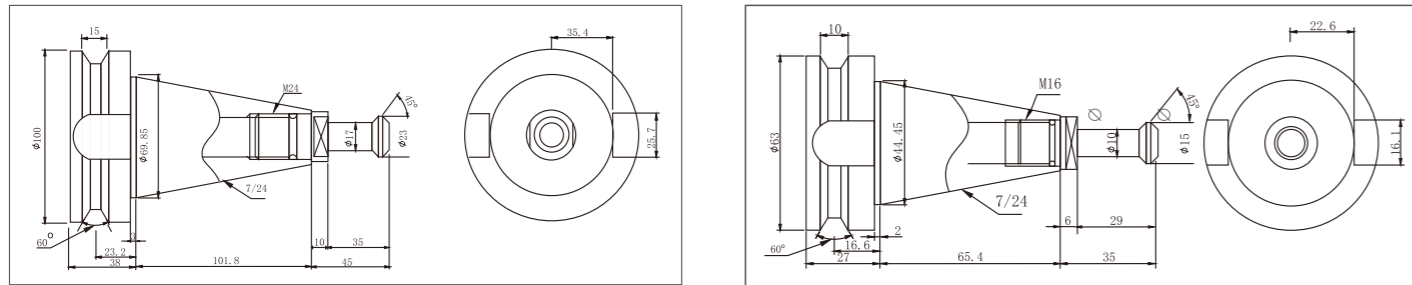

Spindle

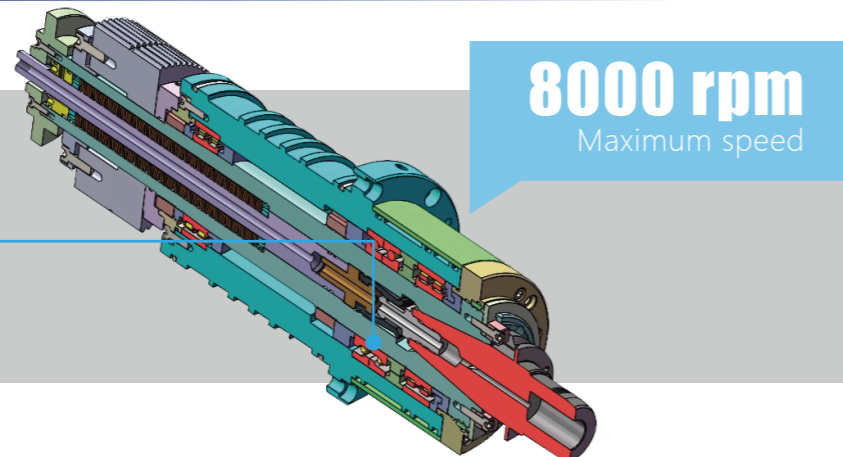

High rigidity and high precision angular contact bearing

8000 rpm
Maximum speed

- The spindle of gantry machining center has smooth rotation characteristics, excellent acceleration capability and high reliability. By virtue of motor with built-in encoder, it can achieve high accuracy positioning and control. It uses precision AC spindle motor with a compact structure and high power and high torque characteristics.
- The spindle motor HRV control makes the control more efficient, generates less heat, and is waterproof in line with international standards (IEC).

MOTOR CHARACTERISTIC CURVE

11/15kW

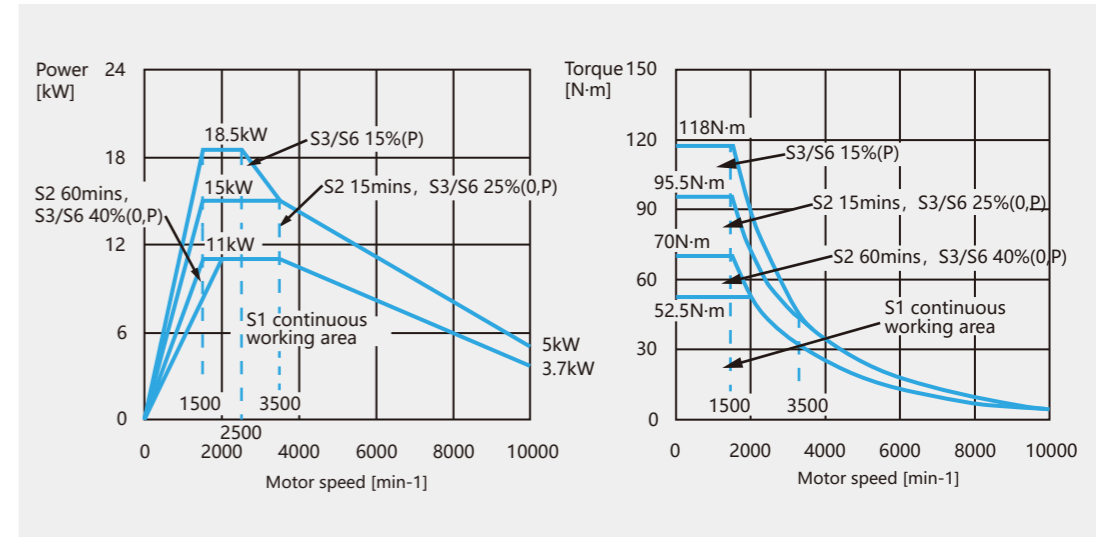

15/18.5kW

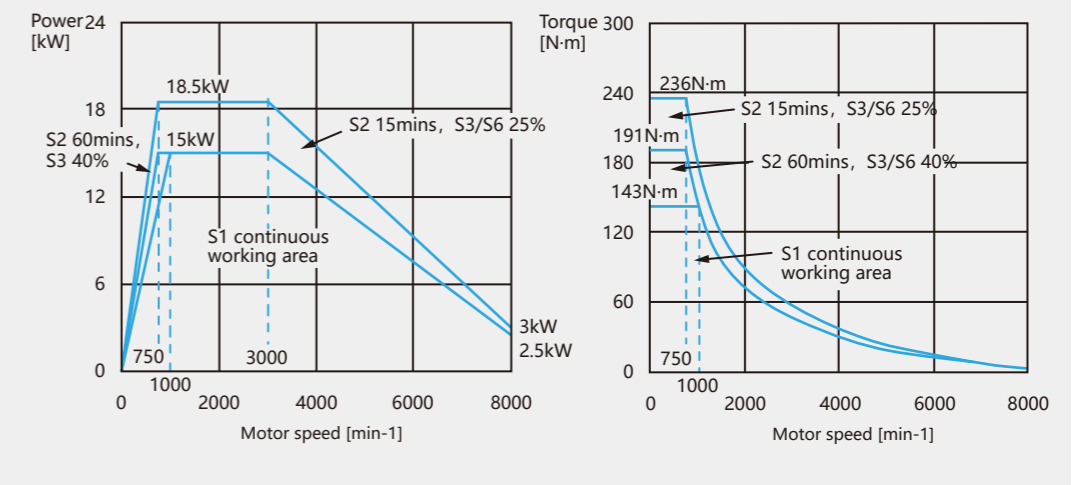

22/26kW

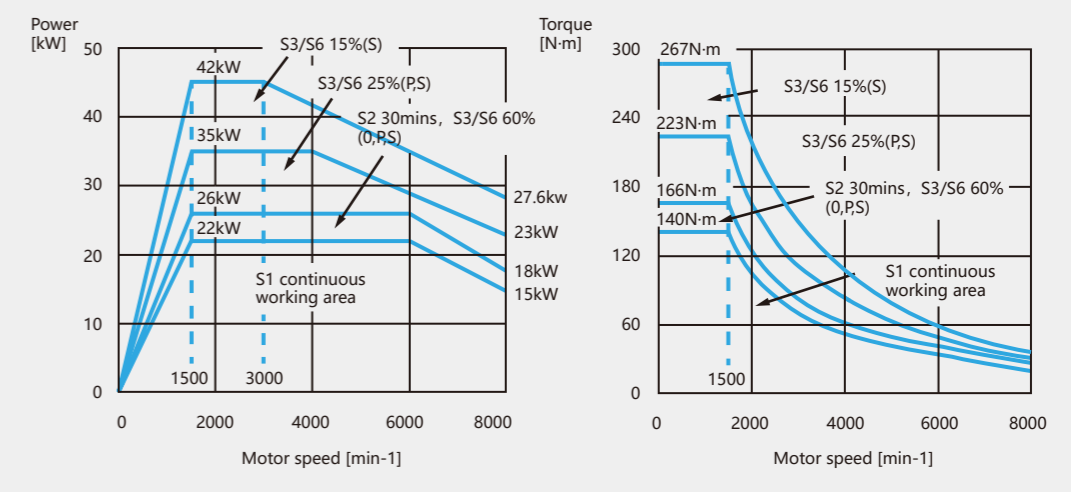

CNC SYSTEM



Hardware configuration

Number of controlled axes: three coordinate axes of X, Y and Z and one spindle

Number of axes in synchronization: X, Y and Z axes

Operating panel: full-featured CNC keyboard

Human-machine communication interface: standard configuration PCU50

Input/output module: separate type 57-300 input/output module extended through IM361 interface module

CNC function

Compensation functions: backlash compensation, over-quadrant error compensation, more flexible tool length and tool radius compensation, and thermal compensation (optional)

Feed functions: feed override adjustment, feed rate per minute, feed rate per revolution, and programmable acceleration limit.

Spindle functions: spindle speed function, spindle override adjustment, spindle orientation exact stop, and speed limit.

Basic functions

Data transmission

USB data input and output.

Edit function

Program block search, program number search, background editing, teaching programming, and program protection.

Operation mode

AUTO mode, stand-alone DNC mode, MDI mode, teaching mode, incremental mode, trial run mode, and single block mode.

Security function

Program test function, programmable processing domain limit, software limit monitoring, hardware limit monitoring, emergency stop, static monitoring, speed monitoring, position monitoring, and contour monitoring.

CNC programming

Fixed cycles for drilling, milling and boring processes, metric/imperial measurement programming, absolute or incremental programming, macro program, plane selection, and workpiece coordinate system

Display function

Current position display, actual cutting speed display, program display, operation error display, alarm information display, and self-diagnosis function display.

Interpolation type

Positioning, exact stop, three-coordinate linear interpolation, arbitrary two-coordinate circular interpolation, spiral interpolation, feed pause, and thread cutting.

STANDARD CONFIGURATION

- FANUC control system: 10.4-inch screen
- Workpiece cooling device
- Automatic lubrication device
- Sheet metal protective cover
- X/Y-axis protective cover
- Pneumatic tool release button + foot switch
- Cleaning air gun water gun
- Transformer
- Electrical cabinet heat exchanger
- Detachable handwheel
- Work light
- Tri-color warning light
- Pneumatic filter
- Spindle air curtain protection
- Internal double coil type conveyor + chain chip conveyor water tank and chip collecting trolley
- Z-axis nitrogen balance system



Spiral chip conveyor

Simple installation, stable operation and low noise.



Heat exchanger

Effectively block moisture, oil, gas, and dust from entering the electrical control box.



Workpiece cooling device

Adjustable machining flushing or air blowing can quickly take away chips and heat generated during machining, improving the finish of the processed surface.



Pneumatic filter

Imported pneumatic unit, precision filtration to keep the air source clean, gives alarm when low pressure.



Chain chip conveyor

It has fast chip conveying speed and high working efficiency, and can be used for various chips such as steel, cast iron, copper, aluminum and non-metals.

100% full inspection for each machine



Laser detection

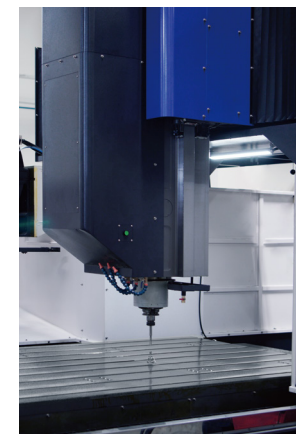

Spindle deflection detection



Circle detection

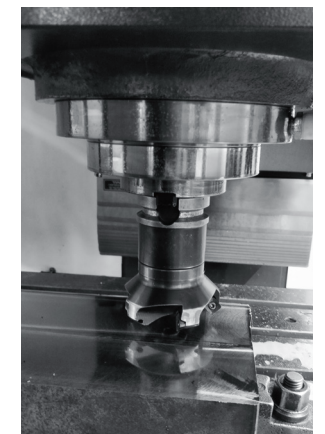

Maximum torque heavy cutting

OPTIONAL CONFIGURATION

- Automatic tool changer (ATC arm)
- Spindle oil cooling device
- Coolant through spindle
- Oil-water separator
- CNC rotary table (fourth axis)
- Tool setter
- Manual/automatic side milling head
- Gearbox
- Optical linear encoder



Oil cooler

Maintain a constant temperature to ensure the spindle machining accuracy, and the constant temperature and room temperature synchronization mode can be selected.



Gearbox

Use 1:4 deceleration to achieve low speed and high torque machining.



Oil-water separator

Effectively remove oil slick from the cutting fluid, maintain the cutting fluid performance and prolong the service life of the cutting fluid.



Tool setter

Improve work efficiency and ensure machining accuracy.

DETAILED DIMENSIONS

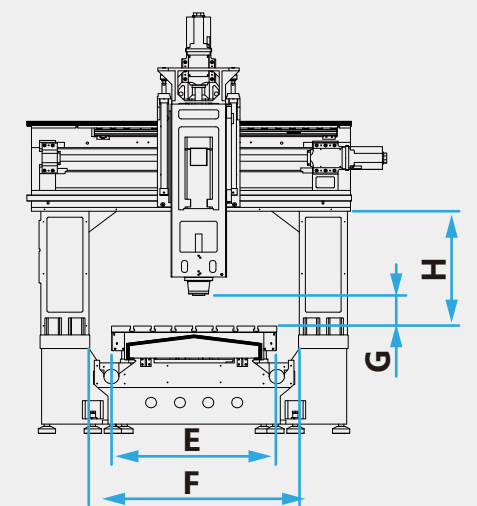
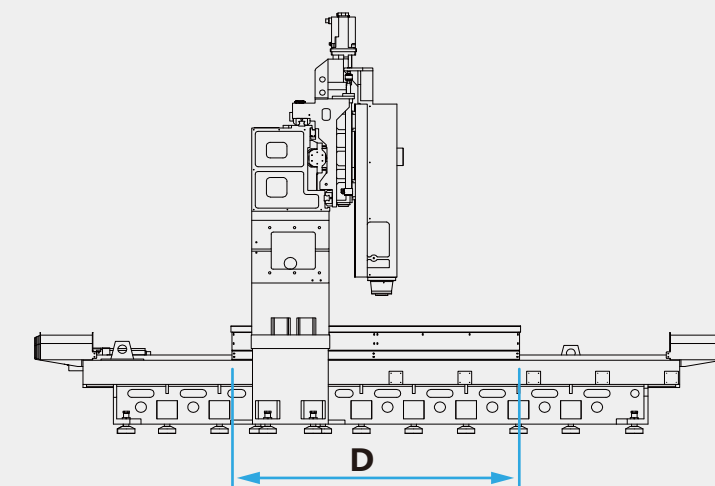
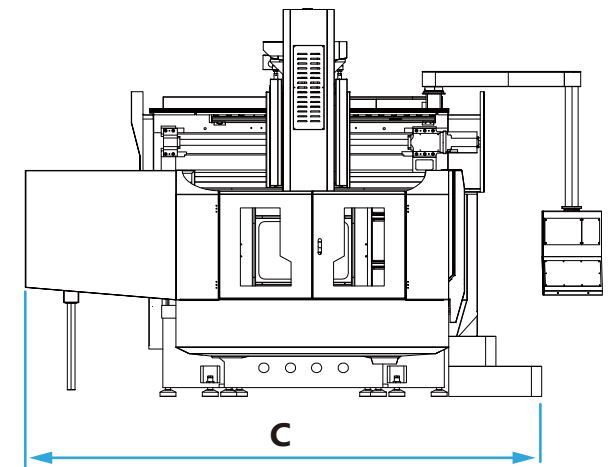
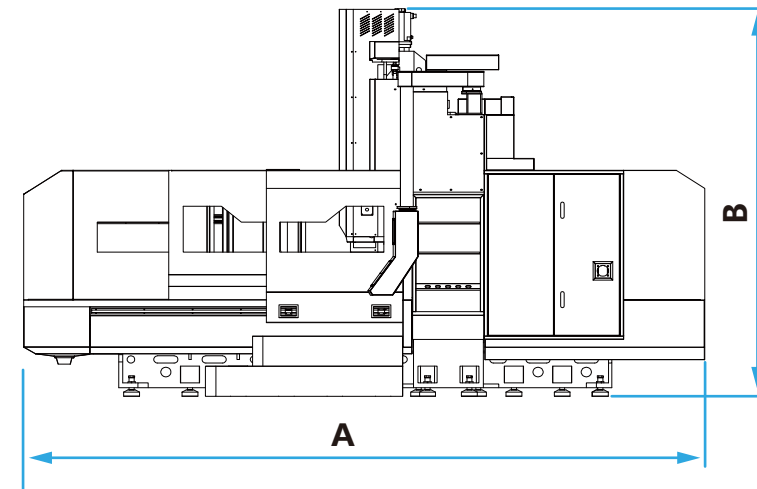

APPLICABLE AREAS

This series of machine tools has strong overall rigidity and flexible and convenient operation, and is suitable for machining large sheet metal parts, box parts, molds, etc. After the clamping of parts, multiple processes such as milling, boring, drilling (drilling, chamfering and reaming), tapping and countersinking can be implemented. This machine tool is widely used in automobile industry, construction machinery, High-end Equipment Manufacturing industry, household appliance mold, mold base machining and other industries with multiple processes, high requirements and high efficiency, and can be used in mechanical manufacturing and other manufacturing industries also.

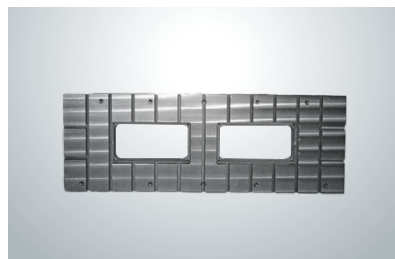
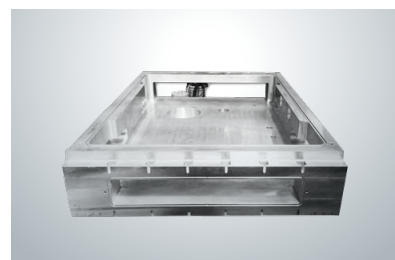

+ Detailed dimensions

Unit: mm

| Model | A | B | C | D | E | F | G | H |
|----------|-------|------|------|------|------|------|-----|------|
| LM-1613L | 4450 | 3200 | 4024 | 1700 | 1200 | 1400 | 200 | 870 |
| LM-2015 | 5365 | 3700 | 4065 | 2100 | 1200 | 1500 | 170 | 1000 |
| LM-2518 | 7120 | 4750 | 4510 | 2500 | 1600 | 1800 | 150 | 1300 |
| LM-3023 | 7830 | 5200 | 5370 | 3000 | 2000 | 2300 | 280 | 1400 |
| LM-4027 | 10280 | 5760 | 5370 | 4000 | 2300 | 2700 | 280 | 1400 |
| LM-5023 | 11830 | 5200 | 5370 | 5000 | 2000 | 2300 | 280 | 1400 |
| LM-6027 | 14280 | 5760 | 5370 | 6000 | 2300 | 2700 | 280 | 1400 |
| LM-8032 | 19740 | 7260 | 6370 | 8000 | 2500 | 3200 | 300 | 1730 |
| HLM-3221 | 8300 | 4650 | 5300 | 3000 | 1800 | 2100 | 150 | 1100 |
| HLM-4221 | 10700 | 4650 | 5300 | 4000 | 1800 | 2100 | 150 | 1100 |

DETAILED PARAMETERS

| | Item | LM-1613L | LM-2015 | LM-2518 | LM-3023 |
|-------------------------------|---|------------------------------|------------------------------|------------------------------|------------------------------|
| Travel | X-axis travel | 1600mm | 2000mm | 2500mm | 3000mm |
| | Y-axis travel | 1300mm | 1500mm | 1800 (full travel 2000) mm | 2200(full travel 2700)mm |
| | Z-axis travel | 800mm | 800mm | 1000mm | 1000mm |
| | Distance from spindle end face to worktable | 170-970mm | 105-905mm | 145-1145mm | 280-1280mm |
| | Gantry passing height | 970mm | 1030mm | 1300mm | 1400mm |
| | Gantry width | 1400mm | 1500mm | 1800mm | 2300mm |
| | Worktable | Worktable size | 1700*1200mm | 2100*1200mm | 2500*1600mm |
| T-type quantity/size/spacing | | 7*22*150 | 7*22*170 | 9*22*180 | 9*28*200 |
| Maximum load-bearing capacity | | 3000kg | 3500kg | 7000kg | 10000kg |
| Spindle | Spindle speed | 50-12000rpm | 50-12000rpm | 50-6000rpm | 50-6000rpm |
| | Drive mode | Direct drive | Direct drive | Belt drive | Belt drive |
| | Spindle motor torque (rated/maximum) | 52.5/118N·m | 52.5/118N·m | 143/236N·m | 143/236N·m |
| | Main motor power | 11/15Kw | 11/15Kw | 15/18.5Kw | 15/18.5Kw |
| Servo axis | X/Y/Z rapid traverse speed | 15/18/18m/min | 15/15/15m/min | 12/15/10m/min | 12/10/10m/min |
| | Cutting feed rate | 1-10000mm/min | 1-10000mm/min | 1-10000mm/min | 1-8000mm/min |
| | Counterweight method | None | Nitrogen counterweight | Nitrogen counterweight | Nitrogen counterweight |
| | Minimum feed | 0.001mm | 0.001mm | 0.001mm | 0.001mm |
| Tool magazine | Tool magazine type | ATC tool magazine (optional) | ATC tool magazine (optional) | ATC tool magazine (optional) | ATC tool magazine (optional) |
| | Shank specification | BT-40 | BT-40 | BT-50 | BT-50 |
| Others | Maximum tool length | 300mm | 300mm | 300mm | 300mm |
| | Machine tool footprint and height | 4450*4024*3200 | 5365*4065*3700 | 7040*4470*4890 | 7830*5200*5370 |
| | Machine tool weight(apx.) | 11000kg | 13500kg | 26000kg | 35000kg |
| | CNC system | FANUC 0iMF PLUS | | | |

(The company's products are continuously improved. The above information is subject to change without prior notice.)

| | Item | LM-4027 | LM-5023 | LM-6027 | LM-8032 |
|-------------------------------|---|------------------------------|------------------------------|------------------------------|------------------------------|
| Travel | X-axis travel | 4000mm | 5000mm | 6000mm | 8000mm |
| | Y-axis travel | 2700(full travel 3050)mm | 2200(full travel 2700)mm | 2700(full travel 3050)mm | 3200(full travel 3800)mm |
| | Z-axis travel | 1000mm | 1000mm | 1000mm | 1250mm |
| | Distance from spindle end face to worktable | 280-1280mm | 280-1280mm | 280-1280mm | 300-1550mm |
| | Gantry passing height | 1400mm | 1400mm | 1400mm | 1730mm |
| | Gantry width | 2700mm | 2300mm | 2700mm | 3200mm |
| | Worktable | Worktable size | 4000*2300mm | 5000*2000mm | 6000*2300mm |
| T-type quantity/size/spacing | | 11*28*200 | 9*28*200 | 11*28*200 | 11*28*200(两侧2*28*180) |
| Maximum load-bearing capacity | | 12000kg | 14000kg | 18000kg | 30000kg |
| Spindle | Spindle speed | 50-6000rpm | 50-6000rpm | 50-6000rpm | 50-6000rpm |
| | Drive mode | Belt drive | Belt drive | Synchronous belt drive | Belt drive |
| | Spindle motor torque (rated/maximum) | 140/223N·m | 140/223N·m | 140/223N·m | 140/223N·m |
| | Main motor power | 22/26Kw | 22/26Kw | 22/26Kw | 22/26Kw |
| Servo axis | X/Y/Z rapid traverse speed | 10/10/10m/min | 10/12/10m/min | 10/10/10m/min | 8/10/10m/min |
| | Cutting feed rate | 1-8000mm/min | 1-8000mm/min | 1-8000mm/min | 1-6000mm/min |
| | Counterweight method | Nitrogen counterweight | Nitrogen counterweight | Nitrogen counterweight | Nitrogen counterweight |
| | Minimum feed | 0.001mm | 0.001mm | 0.001mm | 0.001mm |
| Tool magazine | Tool magazine type | ATC tool magazine (optional) | ATC tool magazine (optional) | ATC tool magazine (optional) | ATC tool magazine (optional) |
| | Shank specification | BT-50 | BT-50 | BT-50 | BT-50 |
| Others | Maximum tool length | 300mm | 300mm | 300mm | 300mm |
| | Machine tool footprint and height | 10300*5760*5050 | 11830*5200*5370 | 14300*5760*5050 | 20300*6970*5470 |
| | Machine tool weight(apx.) | 42000kg | 43000kg | 54000kg | 97000kg |
| | CNC system | FANUC 0iMF PLUS | | | |

(The company's products are continuously improved. The above information is subject to change without prior notice.)

DETAILED PARAMETERS

| Item | HLM-3221 | HLM-4221 | |
|---------------------------|---|------------------------------|------------------------------|
| Travel | X-axis travel | 3200mm | 4200mm |
| | Y-axis travel | 2100mm | 2100mm |
| | Z-axis travel | 950mm | 950mm |
| | Distance from spindle end face to worktable | 150-1100mm | 150-1100mm |
| | Gantry passing height | 1270mm | 1270mm |
| | Gantry width | 2100mm | 2100mm |
| Worktable | Worktable size | 3000*1800mm | 4000*1800mm |
| | T-type quantity/size/spacing | 11*22*160 | 11*22*160 |
| | Maximum load-bearing capacity | 12000kg | 15000kg |
| Spindle | Spindle speed | 6000rpm | 6000rpm |
| | Drive mode | Belt drive | Belt drive |
| | Spindle motor torque (rated/maximum) | 143/236N·m | 140/223N·m |
| | Main motor power | 15/18.5Kw | 22/26Kw |
| Servo axis | X/Y/Z rapid traverse speed | 12/10/10m/min | 10/10/10m/min |
| | Cutting feed rate | 1-8000mm/min | 1-8000mm/min |
| | Counterweight method | Nitrogen counterweight | Nitrogen counterweight |
| | Minimum feed | 0.001mm | 0.001mm |
| Tool tool magazine | Tool magazine type | ATC tool magazine (optional) | ATC tool magazine (optional) |
| | Shank specification | BT-50 | BT-50 |
| | Maximum tool length | 300mm | 300mm |
| Others | Machine tool footprint and height | 8300*5300*4650 | 10700*5300*4650 |
| | Machine tool weight(apx.) | 23500kg | 27500kg |
| | CNC system | FANUC 0iMF PLUS | |

(The company's products are continuously improved. The above information is subject to change without prior notice.)