

US WHEELER

HANGZHOU WHEELER GENERAL MACHINERY INCORPORATED CO.,LTD

Add:
NO.288 Shunfeng Road,Linping District

Tel:
+86 571 8369 5216

Fax:
+86 571 8369 5836

E mail:
info@wheeler-us.com

HM Series

HORIZONTAL MACHINING CENTER



400 780 1898

24/7 Service Hotline.

Machine Tool Lifetime Service

We provide on-call service 24/7. If you encounter any equipment maintenance and repair problems, please contact us. If you have any suggestions, please log in to the company's official website to leave a message.

www.wheeler-us.com



Sample parameters and information are subject to change without prior notice, and the final data is subject to the technical agreement.

HL-HM02309-02-1000



For more information
please follow
Official WeChat account

US WHEELER

INDUSTRIAL ROBOT/
CNC MACHITOLS/
SMART FACTORY

ABOUT US

Hangzhou Wheeler Intelligent General Machinery Incorporated Co.,Ltd is a national high-tech enterprise focusing on CNC machining equipment, machine tool loading and unloading automation, digital factories, and non-standard fixture design and manufacturing. The company was established in January 2015, and its operation center is located in Linping Economic Development Zone, Hangzhou. The company currently has more than 300 employees and an efficient professional technical R&D team, including more than 60 professional and technical personnel with various intermediate and senior technical titles (engineers). The company has a 5,000 square meter R&D center and a 43,000 square meter production and debugging base, and owns more than 50 patent technologies. It has offices and after-sales service outlets in Shanghai, Jiangsu, Anhui, Shandong, Henan, Jilin, Chongqing, Ningbo, Taizhou, Wuhan, Xi'an, Zhengzhou, etc. The company's products are exported to Turkey, Egypt, South Africa, Brazil, Australia, Singapore, Malaysia, Thailand and other countries.

Our
Certification



The company's main products include machining equipment, machine tool loading and unloading robots, machine tool fixtures, peripheral automated logistics equipment, and robot integration systems. It is a strategic partner of robot companies such as Germany's KUKA and Switzerland's ABB. It provides customers with mechanical processing automation technology solutions, a full set of automation equipment, technical consulting, and comprehensive after-sales and technical services. The products are widely used in mass production industries such as automotive parts processing and engineering machinery.



HM Series Horizontal High-speed Machining Center

The HM series high rigidity roller guide horizontal machining center integrates international advanced design concepts; Inverted T shaped bed, front hanging box layout, moving column structure, large span design, high rigidity and strength; The three-axis high rigidity roller guide rail achieves a perfect combination of high precision and high-efficiency machining.



+ Processing characteristics

The HM series horizontal machining center is particularly suitable for rough and precision machining of various box parts;

By using high acceleration/deceleration axis feed, the positioning time has been shortened, and by using high-speed spindle, high-speed ATC, and high-speed drilling, it has become one of the mainstream machine tools in the world, significantly reducing the processing cycle.

This machine series has been widely used in mechanical processing fields such as automobiles, High-end Equipment Manufacturing, rail transit, petroleum valves, plastic machinery, mining machinery, and

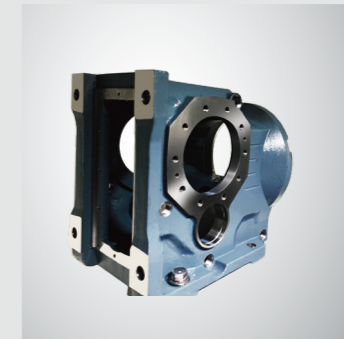
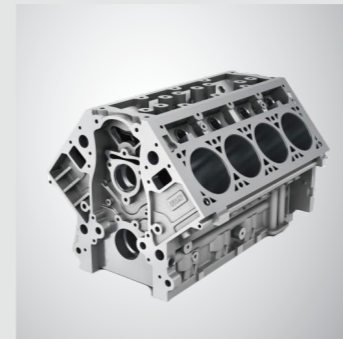
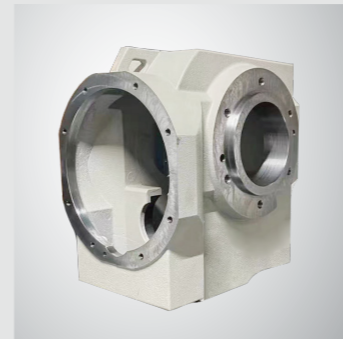

MECHANICAL STRUCTURE

Inverted T-shaped Bed

The HM series high rigidity roller guide horizontal machining center integrates international advanced design concepts; Inverted T-shaped bed, front hanging box layout, three axis high rigidity roller guide rail achieve perfect integration of high precision and efficient processing.

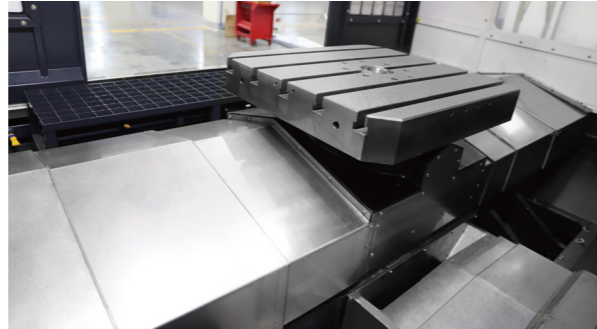

High Rigidity Roller Guide Way

A planar linear motion with high load-bearing capacity, rigidity, responsibility, and performance. Under heavy or variable loads, the elastic deformation is small and stable linear motion can be achieved, with excellent mechanical positioning accuracy



structure characteristics

After a single clamping process, the horizontal machining center completes multi process automatic machining, automatically selects and replaces cutting tools, automatically changes the spindle speed and feed rate of the machine tool, automatically changes the motion trajectory of the cutting tool and the workpiece, and automatically realizes other auxiliary functions.

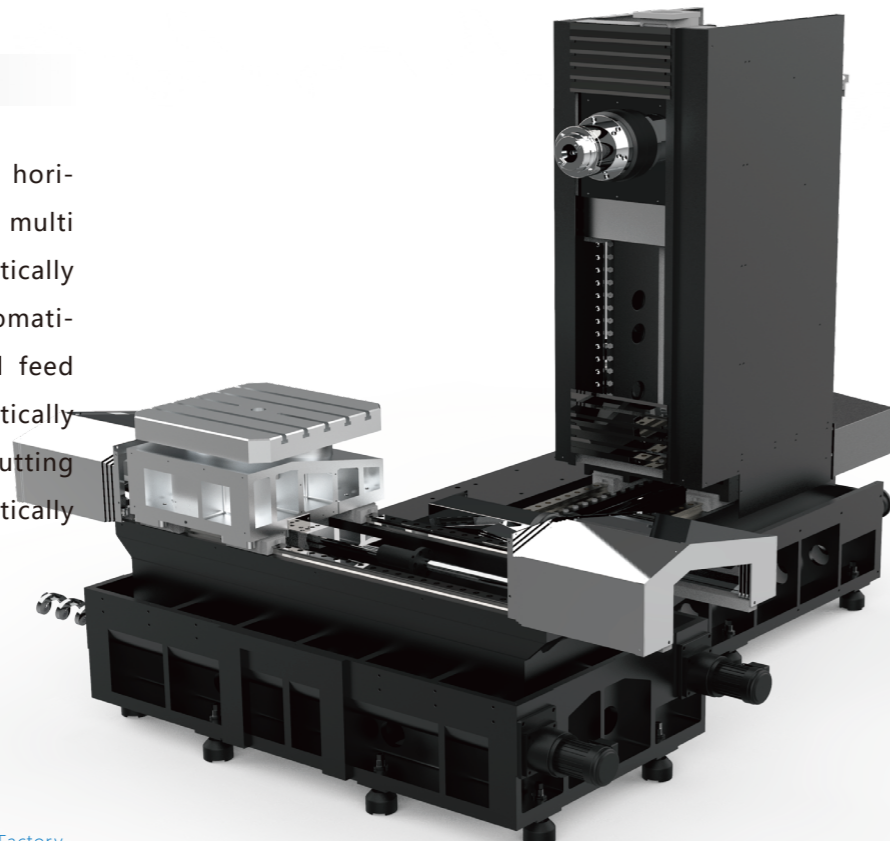

SPINDLE

Efficient and High-performance Spindle

8000 rpm
最高转速

High rigidity
high precision
angular contact bearings

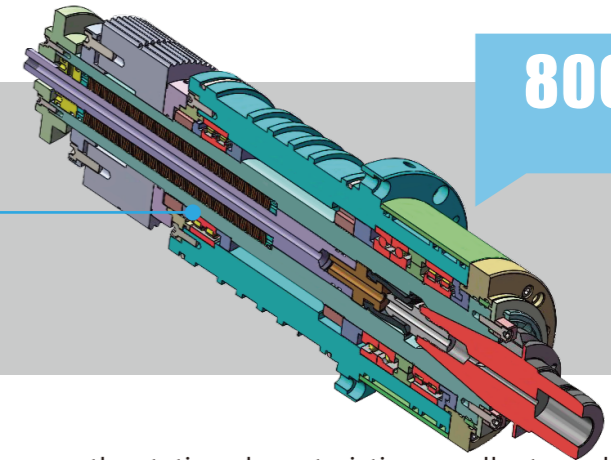

- The spindle of a horizontal machining center has smooth rotation characteristics, excellent acceleration ability, and high reliability. When paired with a built-in encoder in the motor, high-precision positioning and control can be achieved. Select a precision ACspindle motor with a compact structure and high power and torque characteristics.
- The spindle motor is more efficient, generates less heat, and has a waterproof design that complies with international standards (IEC).

Characteristic Diagram of Spindle Motor

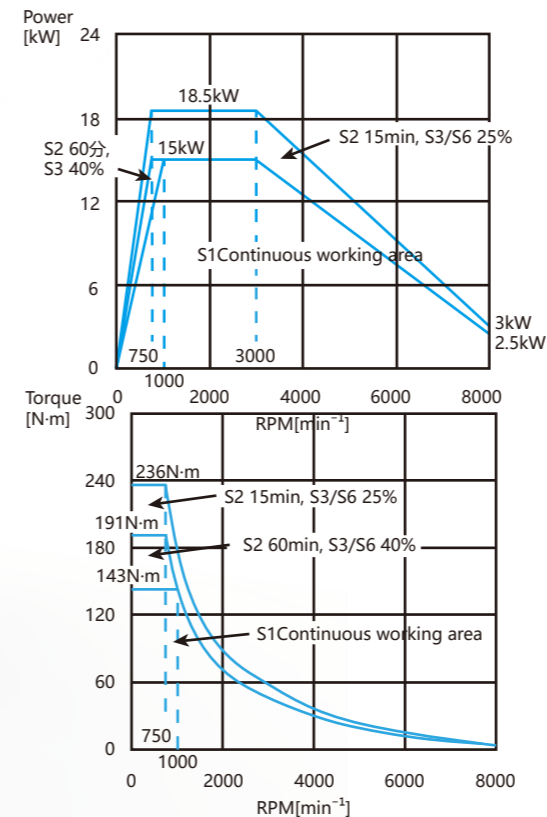

ROTARY TABLE

Rotary Table

The worktable adopts a complete set of imported professional supporting products from manufacturers, with reliable quality and stable performance, further improving the reliability of the entire machine. The standard configuration of the worktable is a indexing worktable with a mouse tooth disc (1° x 360) positioning, which has high positioning accuracy. Continuous indexing (0.001) positioning NC worktable is optional.

The indexing turntable uses an AC servo motor to realize the rotation of the worktable through a 1:8 gear pair and a pair of 1:30 worm gear. The clamping and loosening of the worktable is realized by an oil cylinder. The rotation position accuracy of the worktable is guaranteed by a high-precision end gear disc.

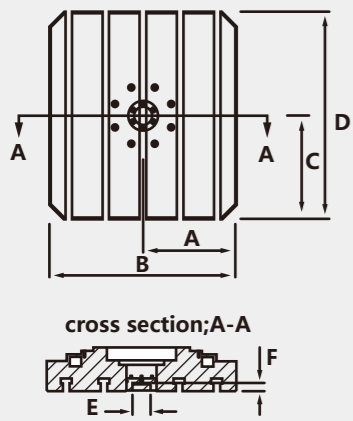

Rotary Table Size

Unit: mm

Model	A	B	C	D	E	F
HS5000	250	500	250	500	Φ50 G6	20
HM6300	315	630	315	630	Φ60 G6	27
HM8000	400	800	400	800	Φ60 G6	27
HM1000	500	1000	500	1000	Φ60 G6	27

Machining range

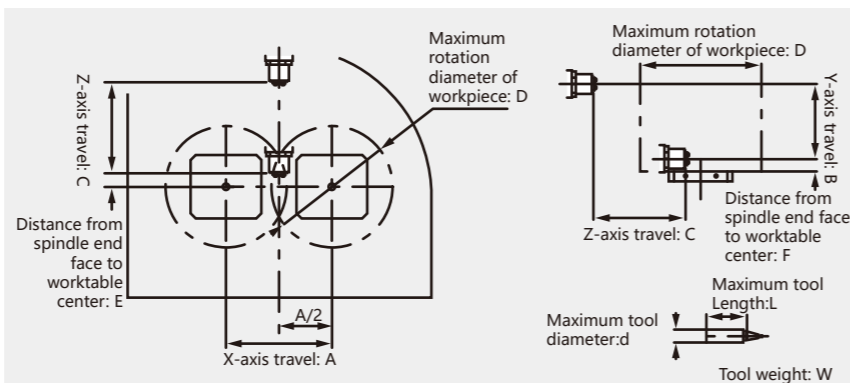

Unit: mm

Model	A	B	C	D	E	F	W (kg)	L	d
HS5000	1100	600	600	700	180-780	-20-580	8	400	150
HM6300	1050	750	900	1200	130-1030	120-870	15	400	200
HM8000	1100	850	900	1600	180-1080	100-950	15	400	200
HM1000	1300	1000	1000	1800	200-1200	120-1120	15	400	200

OPERATION SYSTEM

FANUC - 0iMF PLUS

The biggest advantage of FANUC CNC system is its open design, mainly manifested in three aspects: human machine interface, PLC, and NC. The system has added multiple interpolation functions to provide users with more technical support.

The system integrates many practical computer functions, perfectly integrating CAD and CAM software with CNC systems, integrating product modeling, automatic programming, and simulation processing; Truly achieved intelligent control.

The keyboard like operation panel greatly shortens the user's learning and adaptation cycle, and reduces learning costs.



0iF Plus System Storage Capacity Dramatically Increased

- System processing program storage capacity comes standard with 2M+1000 programs
- Using FANUC program transfer software can support online program editing
- PMC series comes standard with 24000 steps, program capacity expands
- PMC series comes standard with MEM B
- User software capacity 6M



STANDRAD CONFIGURATION

- FANUC control system: 10.4-inch screen

- Workpiece cooling device

- Automatic lubrication device

- Sheet metal full protective cover

- Protective covers for each axis

- Automatic tool changing device (ATC arm)

- Transformer

- Electrical cabinet heat exchanger

- Separate handwheel

- Work lights

- Tri color warning lights

- Pneumatic filtration device

- Automatic door for ATC

- Internal coil type conveyor+chain type chip conveyor, water tank and chip cart

- Bottom flushing

- Cleaning air gun and water gun



Bottom flushing

Quickly clean accumulated debris and keep the interior of the machine clean.



Workpiece cooling device

Adjustable processing flushing or blowing can quickly remove chips and heat generated during processing, improving the smoothness of the processed surface.



Chain chip conveyor

The chip conveying speed is fast, the work efficiency is high, and it is suitable for various chips such as steel parts, cast iron, copper, aluminum, and non-metallic materials.



Heat exchanger

Effectively block moisture, oil, and dust from entering the electrical control box.



Pneumatic filtration device

Imported pneumatic two-piece, precision filtration to maintain the cleanliness of the air source, and low pressure alarm.

OPTIONAL CONFIGURATION

- Spindle oil cooling device

- Coolant through spindle

- Oil water separator

- Tool setter

- Optical linear encoder

- Gear box



Oil cooler

Maintain a constant temperature to ensure the machining accuracy of the spindle, and synchronous mode of constant temperature and room temperature is available as option.



Gear box

1: 4. Reduce speed to achieve low-speed and high torque machining.



Oil water separator

Effectively remove floating oil from cutting fluid, maintain cutting fluid performance, and extend the service life of cutting fluid.

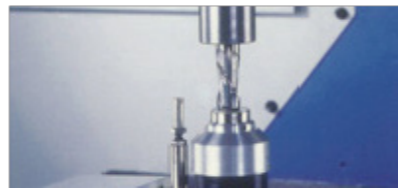

Tool setter

Improve work efficiency and ensure machining accuracy.

AUTOMATIC MANUFACTURE LINE

Horizontal machine tray system



Production line configuration

1 horizontal machine, 1 pallet magazine, 1 rotary stacker, 1 loading and unloading workstation, 1 safety protection system, and 1 control system

Characteristics of the production line

Compact structure that saves space and costs.
 Servo driven stable and high precision Can achieve long-term unmanned operation Realize the demand for multi variety and small batch production Increase equipment utilization rate, reduce machine tool downtime

Flexible robotics system

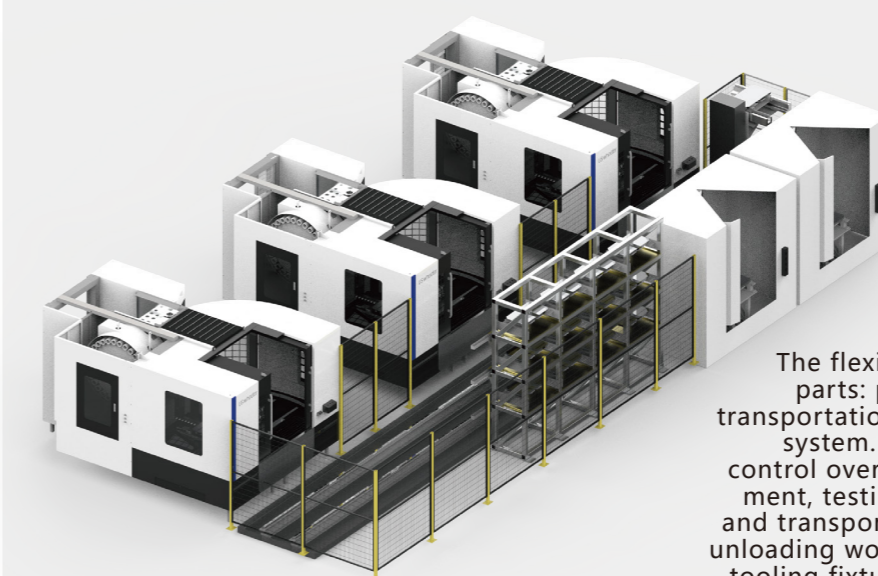

Production line configuration

3 horizontal machines, 1 ground rail robot, 1 set of robotic arms for grabbing, 2 loading and unloading workstations, 1 set of pallet material storage, 1 set of zero point positioning system, etc

Characteristics of the production

The flexible control system includes three major parts: processing system, material storage and transportation system, and control and management system. The processing system provides unified control over processing equipment, auxiliary equipment, testing equipment, etc; The material storage and transportation system manages the loading and unloading workstation, pallet & material warehouses, tooling fixtures, cutting tools, etc. at a system level; Control and management systems are used to achieve process control, scheduling, and monitoring of flexible robot systems.

MACHINE DIMENSION

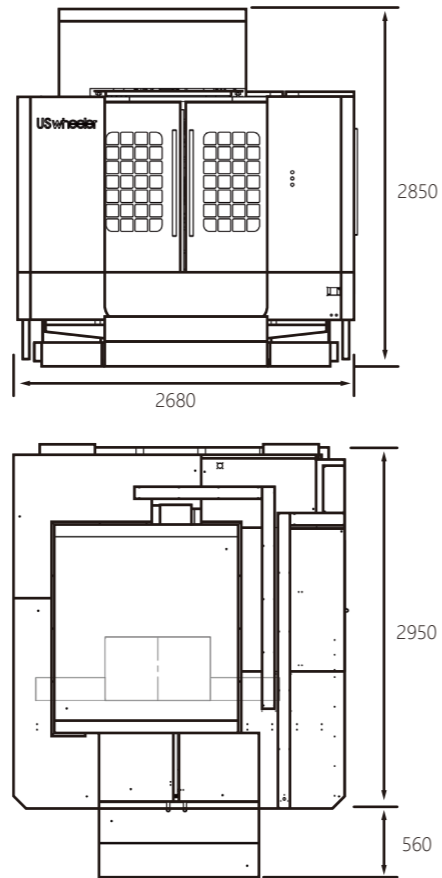
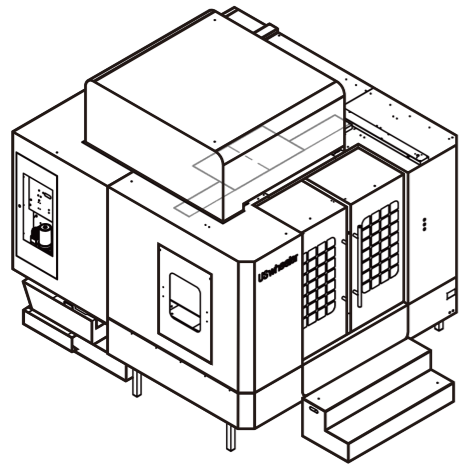

Item	HS5000
Length	2680 mm
Width	2950 mm
Height	2850 mm
Weight	7500 kg

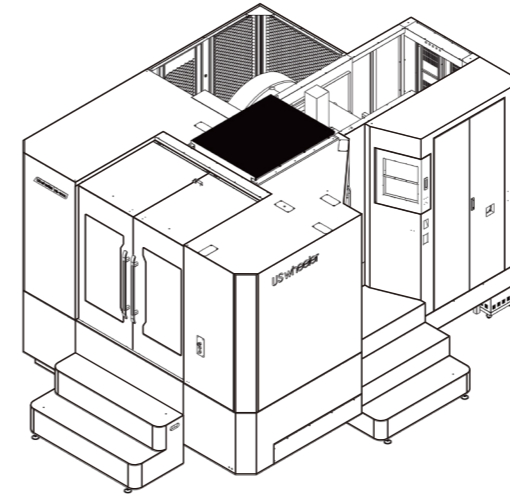

Item	HM8000
Length	5215 mm
Width	4000 mm
Height	3100 mm
Weight	14000 kg

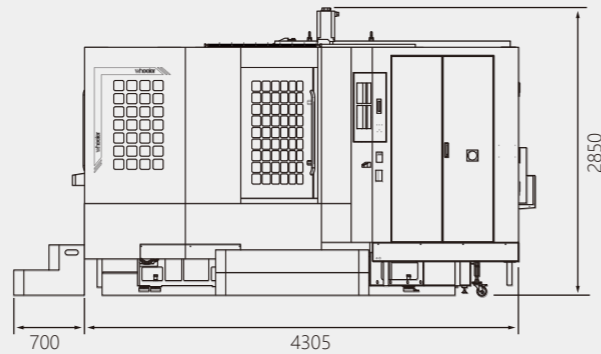
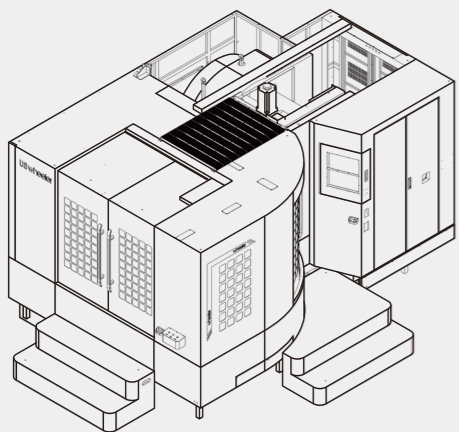
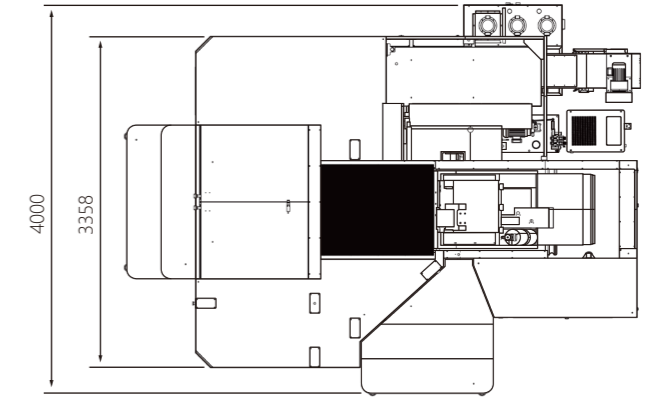
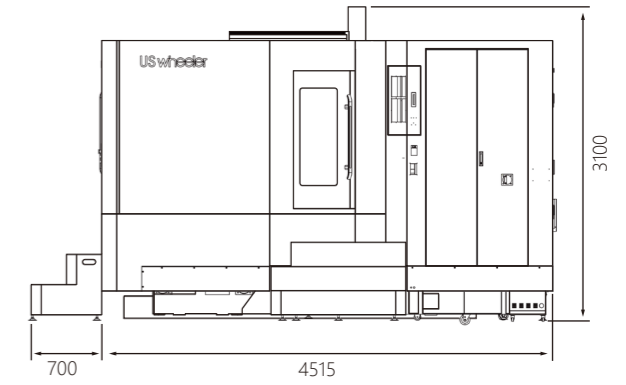

Item	HM6300
Length	5005 mm
Width	4000 mm
Height	2850 mm
Weight	12000 kg

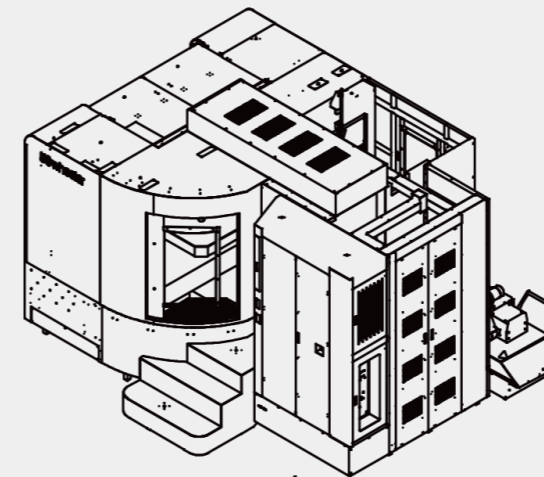
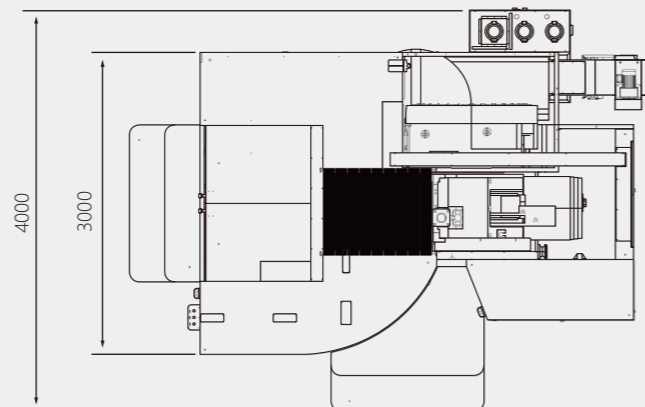

Item	HM1000
Length	5865 mm
Width	4350 mm
Height	3200 mm
Weight	18000 kg

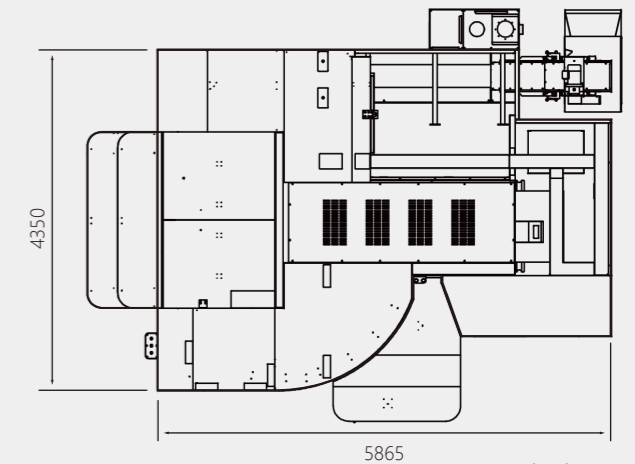
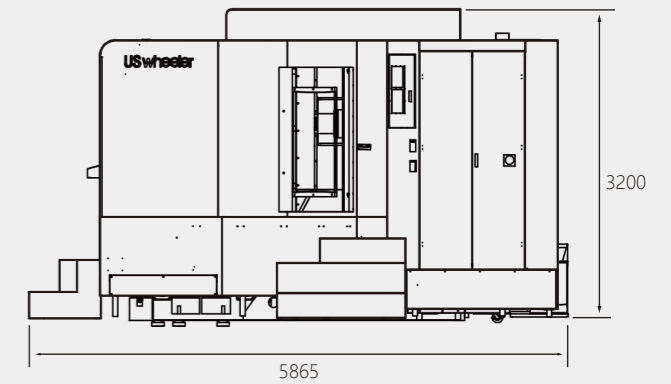

DETAILED PARAMETERS

		HS 5000	HM 6300
Machining range	X direction	mm	1100
	Y direction	mm	600
	Z direction	mm	600
	Distance from the centerline of the spindle to the worktable	mm	-20~580
	Distance from spindle end face to worktable center	mm	180~780
Workable	Worktable size	mm	500*500
	Worktable indexing	°	1°x360
	Maximum load of worktable	kg	350
	Maximum turning diameter of the worktable	mm	Φ700
Spindle	Drive mode	-	Direct - drive
	Spindle speed	rpm	50-10000
	Motor power	kW	11/15
	Spindle motor torque (rated/maximum)	Nm	52.5/118
Servo motor	Spindle taper and specifications	-	BT40
	X, Y, Z Fast moving speed	m/min	36/36/36
	B Axis fast moving speed	r/min	8
	Feed rate	mm/min	1-10000
	Minimum feed rate	mm	0.001
ATC	ATC capacity	No.	24
	ATC form	-	ATC
	Tool holder specifications	-	BT40
	Tool holder pull studs	-	P-40T 45°
	Maximum tool diameter (adjacent)	mm	80
	Maximum tool diameter (no adjacent tools)	mm	150
	Maximum tool length	mm	400
	Maximum weight of cutting tool	kg	8
Others	Machine weight	kg	6500
	Exterior dimensions (length * width * height)	mm	2680*2950*2850
	Power capacity	kVA	35
	Lubricant Capacity	L	3
	Cutting fluid capacity	L	300
	Air pressure	bar	6~8
	CNC system	FANUC - 0iMF PLUS	

		HM 8000	HM 1000
Machining range	X direction	mm	1100
	Y direction	mm	850
	Z direction	mm	900
	Distance from the centerline of the spindle to the worktable	mm	100~950
	Distance from spindle end face to worktable center	mm	180-1080
Workable	Worktable size	mm	800*800
	Worktable indexing	°	1°x360
	Maximum load of worktable	kg	1500
	Maximum turning diameter of the worktable	mm	Φ1600
Spindle	Drive mode	-	Belt -Drive
	Spindle speed	rpm	50-6000
	Motor power	kW	15/18.5
	Spindle motor torque (rated/maximum)	Nm	143/236
Servo motor	Spindle taper and specifications	-	BT50
	X, Y, Z Fast moving speed	m/min	24/24/24
	B Axis fast moving speed	r/min	10
	Feed rate	mm/min	1-10000
	Minimum feed rate	mm	0.001
ATC	ATC capacity	No.	30
	ATC form	-	ATC
	Tool holder specifications	-	BT50
	Tool holder pull studs	-	P-50T 45°
	Maximum tool diameter (adjacent)	mm	112
	Maximum tool diameter (no adjacent tools)	mm	200
	Maximum tool length	mm	400
	Maximum weight of cutting tool	kg	18
Others	Machine weight	kg	14000
	Exterior dimensions (length * width * height)	mm	5215*4000*3100
	Power capacity	kVA	40
	Lubricant Capacity	L	3
	Cutting fluid capacity	L	300
	Air pressure	bar	6~8
	CNC system	FANUC - 0iMF PLUS	